

Diver 35 & 45 Submersible Pumps

The Diver 35 & 45 submersible pumps offer a solution to lifting clean fresh water only for high head (pressure) requirements.

Incorporating a floating switch to protect against running dry, these pumps are ideal for applications where pressure is needed, such as sprinklers or pumping up to storage tanks.

Boostamatic

These options, with control module remotely located in a dry position, are ideal for irrigation or water supply applications where the pump can be located in a well or pond for instance.

All models carry a 12 month warranty period.

Features

- Fully automated - no switch setting necessary.
- A built in 'no water' safety cut out.
- No pulsating when operating.

Materials

Body	Polypropylene/stainless steel
Impeller	PPO
Motor casing	304 Stainless steel
Pump shaft	304 Stainless/ceramic
Seal	Nit/car/cer

Operating Conditions

Max. liquid temp.	35°C
Min. liquid temp.	4°C
Max. immersion depth	10 m
Cable	H07RN-F3 15 m

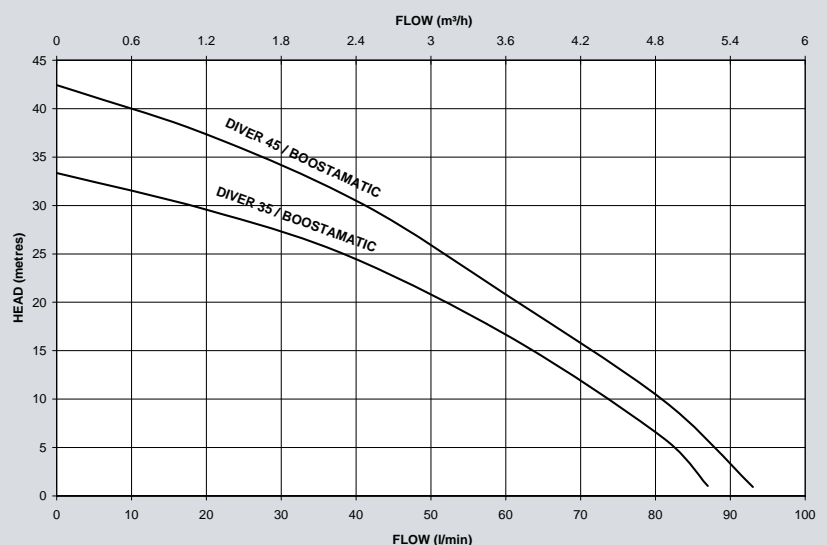

Diver 35 & 45 Submersible Pumps

Model	Motor*	Nominal Watts	Watts full flow	Amps full load	Impeller	Seal	Carton dims. mm			Gross weight (packed) kg	Part no.
							L	x W	xH		
Diver 35	230/1/50	720	774	3.7	PPO	Nit/Car/Cer	180	240	405	8.5	46585
Diver 45	230/1/50	1000	1012	4.7	PPO	Nit/Car/Cer	180	240	405	9.2	46586
Boostamatic Diver 35	230/1/50	720	774	3.7	PPO	Nit/Car/Cer	180	240	580	9.7	46611
Boostamatic Diver 45	230/1/50	1000	1012	4.7	PPO	Nit/Car/Cer	180	240	580	10.4	46612

*Built to IPX8, motors are designed for continuous running and feature thermal overload protection. A residual current device having a rated current not exceeding 30mA must be installed in the supply circuit.

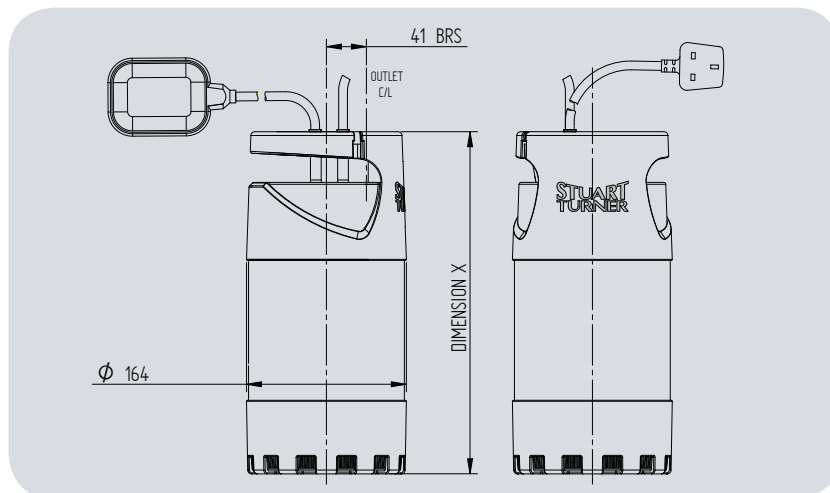

The Diver pumps are supplied complete with hose union, suitable for 25 mm (1") bore hose.

Pump Connection Sizes

Diver 35 & 45	G 1 Female
Control module	
Boostamatic models only	G 1 Male

Pump Description	Dim. X
Diver 35/ Boostamatic Diver 35	350
Diver 45/ Boostamatic Diver 45	387

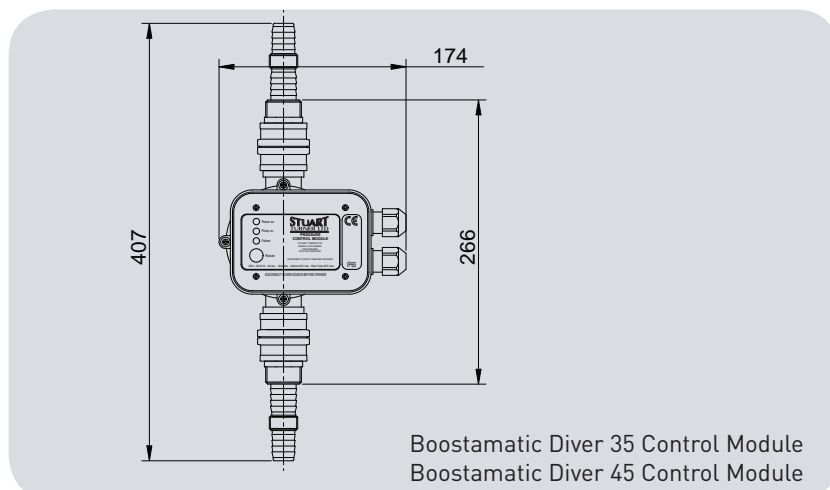

All dimensions shown are in mm.

Stuart Turner Ltd
Henley-on-Thames
Oxfordshire RG9 2AD
England

Telephone:
+44 (0)1491 572655
Fax:
+44 (0)1491 573704

Email:
pumps@stuart-turner.co.uk
Web:
www.stuart-turner.co.uk

**STUART
TURNER**